

SALIENT FEATURES

Fast
Action

Force & Speed
Adjustable

Negligible
Maintenance

Low
Cost

Energy
Efficient

PNEUMATIC PRESSES

C Frame Type

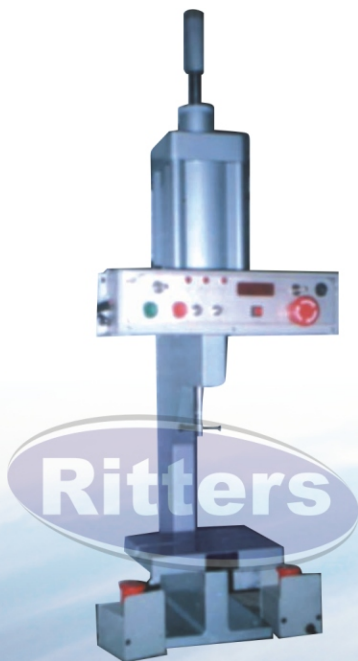

4 Pillar Type



2 Pillar Type



Pneumatic & Hydraulic Products

Ritters Automation Pvt. Ltd.

M-160, Sector-1, DSIDC, Bawana, New Delhi - 110039

Ph. : 27750720-1-2 Fax +91-11-27750719

Email : info@rittersindia.com Website : www.rittersindia.com

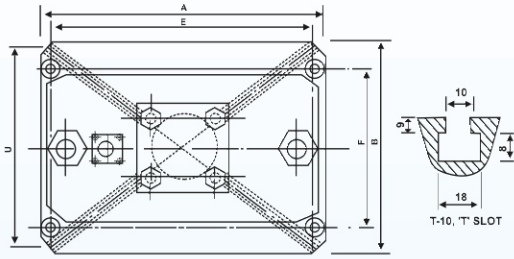

PNEUMATIC PRESS 2 - PILLAR TYPE

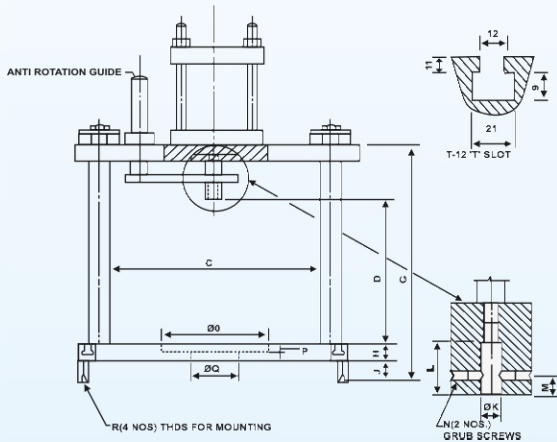

Model No.	Force	A	B	C	D	E	F	G	H	J	K	L	M	N	O	P	Q	R	T
2P - 250	250 KGF	300	200	200	200	250	100	350	30	50	20	25	10	M6	55	17	35	M10	10
2P - 500	500 KGF	330	230	250	250	280	130	410	35	50	20	25	10	M6	55	17	35	M10	10
2P - 1000	1000 KGF	350	250	260	275	300	150	460	38	50	25	30	12	M8	80	17	55	M12	10
2P - 1500	1500 KGF	350	250	260	300	300	150	540	40	60	30	30	12	M8	80	20	55	M12	12
2P - 2000	2000 KGF	400	350	300	350	350	200	650	45	60	30	30	12	M8	90	20	60	M12	12

PNEUMATIC PRESS 4 - PILLAR TYPE

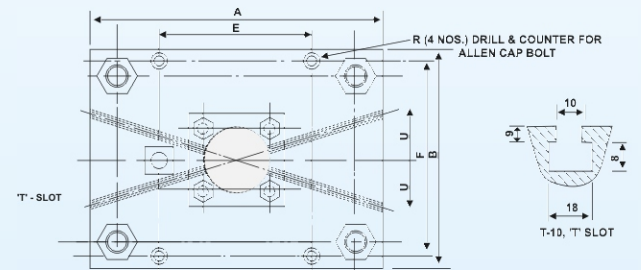

Model No.	Force	A	B	C	D	E	F	G	H	J	K	L	M	N	O	P	Q	R	T	U
4P - 250	250 KGF	300	200	200	200	120	140	350	30	40	20	25	10	M6	55	17	35	M10	10	50
4P - 500	500 KGF	330	230	250	250	140	160	410	35	40	20	25	10	M6	55	17	35	M10	10	60
4P - 1000	1000 KGF	350	250	260	275	180	180	460	38	45	25	30	12	M8	80	17	55	M12	10	70
4P - 1500	1500 KGF	350	250	260	300	200	225	540	40	45	30	30	12	M8	80	20	55	M12	12	80
4P - 2000	2000 KGF	400	350	300	350	275	300	650	45	50	30	30	12	M8	90	20	60	M12	12	125

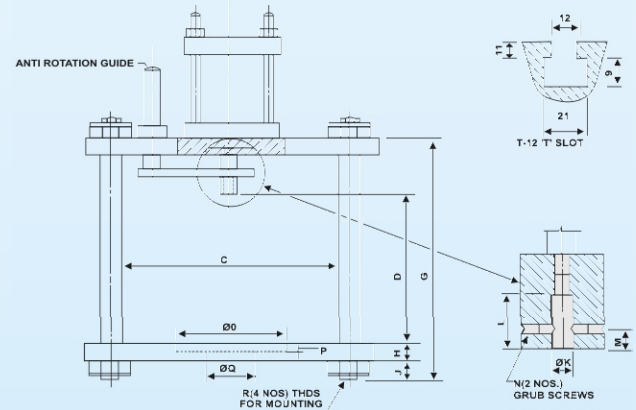

PNEUMATIC PRESS 'C' - FRAME TYPE

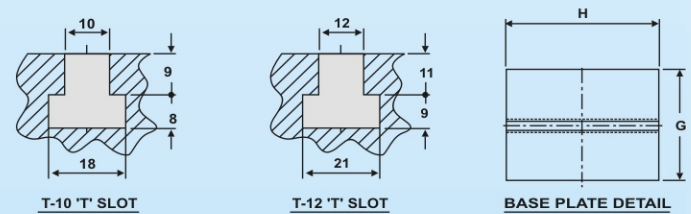
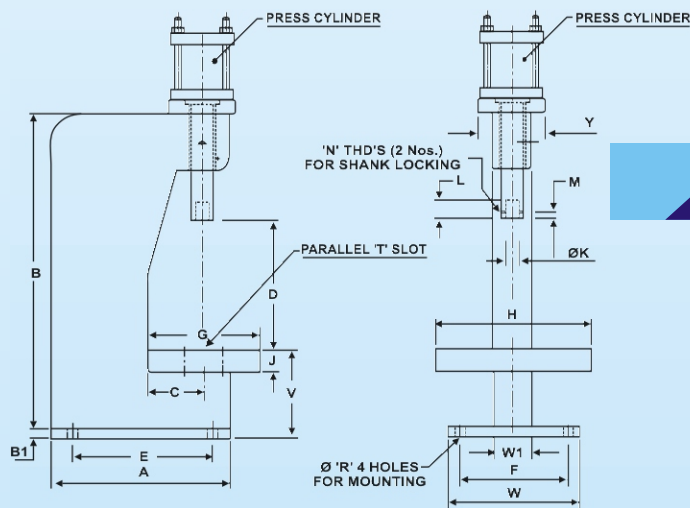

MODEL	Ton	A	B	B1	C	D	E	F	G	H	J	K	L	M	N	R	T	V	W	W1	Y
C-500	0.5	235	380	13	75	150	185	140	150	200	25	15	20	10	M6	13	10	120	170	38	130
C-1000	1.0	270	425	15	75	200	220	170	150	200	25	20	25	12	M8	13	10	125	200	40	180
C-1500	1.5	300	450	15	100	200	260	200	180	250	30	25	25	12	M8	13	12	160	250	45	230